



JOHN DEERE

Marine Applications

Diesel Engine Ratings





CONTENTS

Identification plate	4 – 5
M ratings	6 – 7
Load factor	10
Emissions	11
PowerTech™ 4.5L marine engines	12 – 13
PowerTech 6.8L marine engines	14 – 15
PowerTech 9.0L marine engines	16 – 17
PowerTech 12.5L marine engines	18 – 19
PowerTech 13.5L marine engines	20 – 21
PowerTech marine generator drive engines.....	22 – 23
PowerTech auxiliary generator drive engines	24 – 25
PowerTech auxiliary drive engines	26 – 27
Warranty and service.....	28 – 29



Identification plate

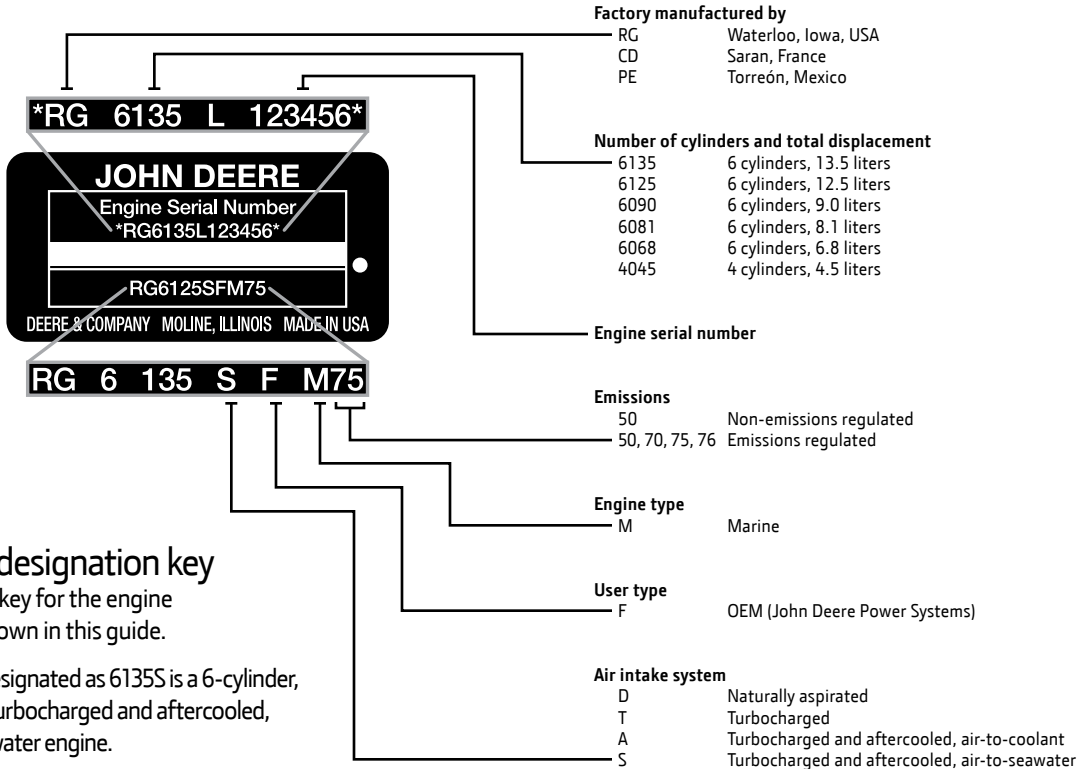

Model designation key

Below is a key for the engine models shown in this guide.

A model designated as 6135S is a 6-cylinder, 13.5-liter turbocharged and aftercooled, air-to-seawater engine.

A model designated as a 4045T is a 4-cylinder, 4.5-liter turbocharged engine.

6135S



M ratings



M1: The M1 rating is for marine propulsion applications that may operate up to 24 hours per day at uninterrupted full power. These applications typically operate more than 3,000 hours per year and have load factors* over 65 percent. The M1 rating is the ISO 8665 standard power rating and the SAE J1228 crankshaft power rating. Both are defined as the power level at which an engine can run continuously between recommended service intervals.

Possible applications: Line haul tugs and towboats, fish and shrimp trawlers/draggers, and displacement hull fishing boats over 18 m (60 ft).

M2: The M2 rating is for marine propulsion applications that operate up to 3,000 hours per year and have load factors* up to 65 percent. This rating is for applications that are in continuous use, and use full power for no more than 16 hours out of each 24 hours of operation. The remaining time of operation must be at cruising† speeds.

Possible applications: Short-range tugs and towboats, long-range ferryboats, large passenger vessels, and offshore displacement hull fishing boats under 18 m (60 ft).

Marine auxiliary power engines for dedicated hydraulic pump drives, dredge pumps, or other constant-load marine applications should use the M2 rating.

* Load factor is the actual fuel burned over a period of time divided by the full-power fuel consumption for the same period of time. For example, if an engine burns 160 liters of fuel during an eight-hour run, and the full-power fuel consumption is 60 liters per hour, the load factor is $160 \text{ liters} / (60 \text{ liters per hour} \times 8 \text{ hours}) = 33.3 \text{ percent}$.

† Cruising is any operating time where the engine speed is more than 200 rpm less than the maximum attainable engine speed.

M3: The M3 rating is for marine propulsion applications that operate up to 2,000 hours per year and have load factors* up to 50 percent. This rating is for applications that use full power for no more than four hours out of each 12 hours of operation. The remaining time of operation must be at cruising† speeds.

Possible applications: Coastal fishing boats, offshore crew boats, research boats, short-range ferryboats, and dinner cruise boats.

M4: The M4 rating is for marine propulsion applications that operate up to 800 hours per year and have load factors* below 40 percent. This rating is for applications that use full power for no more than one hour out of each 12 hours of operation. The remaining time of operation must be at cruising† speeds.

Possible applications: Inshore crew boats, charter fishing boats, pilot boats, dive boats, and planing hull commercial fishing boats.

M5: The M5 rating is for marine recreational propulsion applications that operate 300 hours or less per year and have load factors* below 35 percent. This rating is for applications that use full power for no more than 30 minutes out of each eight hours and cruising† speed the remainder of the eight hours, and do not operate for the remaining 16 hours of the day.

Possible applications: Recreational boats in the U.S., tactical military vessels, and rescue boats outside the U.S.

Marine generator: The marine generator engine rating is the power available under normal varying electrical load factors* for an unlimited number of hours per year in commercial applications. This rating incorporates a 10 percent overload capability, and conforms to ISO 8528 prime power. Average load over a 24-hour period shall not exceed 67 percent of the prime rating, of which no more than two hours are between 100 percent and 110 percent of the prime rating.

The marine generator rating is restricted to generator applications only. The criteria used to establish marine generator application ratings are the same used to establish industrial prime power generator application ratings.

* Load factor is the actual fuel burned over a period of time divided by the full-power fuel consumption for the same period of time. For example, if an engine burns 160 liters of fuel during an eight-hour run, and the full-power fuel consumption is 60 liters per hour, the load factor is $160 \text{ liters} / (60 \text{ liters per hour} \times 8 \text{ hours}) = 33.3 \text{ percent}$.

† Cruising is any operating time where the engine speed is more than 200 rpm less than the maximum attainable engine speed.

Load factor

M rating	Typical load factor	Typical annual usage	Typical full power operation
M5	≤ 35%	≤ 300 hr	0.5 of each 8 hr
M4	≤ 40%	≤ 800 hr	1 of each 12 hr
M3	≤ 50%	≤ 2,000 hr	4 of each 12 hr
M2	≤ 65%	≤ 3,000 hr	16 of each 24 hr
M1	> 65%	> 3,000 hr	Uninterrupted

Emissions

	Commercial	Recreational	Auxiliary
EPA Marine Tier 2 regulations in North America	■	■	■
Engines > 130 kW (174 hp) MARPOL Annex VI	■	■	■
Nonroad mobile machinery (NRMM) (97/68/EC) (As amended)	■	■	■



PowerTech

4.5L marine engines

- Keel-cooled or heat exchanger configurations
- Naturally aspirated or turbocharged, non-aftercooled
- Feature constant power to 400 rpm below rated speed
- Excellent choice for launches, work boats, trawler yachts, and patrol craft



Engine model	Emissions rating	Displacement		Rated power		Rated speed	Rated fuel consumption	
		L	cu in	kW	hp	rpm	L/hr	gal/hr
4045TFM75								
M3	2, 3, 4	4.5	276	101	135	2600	29.4	7.8
M2	2, 3, 4	4.5	276	90	121	2500	25.4	6.2
M1	2, 3, 4	4.5	276	80	107	2400	22.1	5.8
4045TFM50								
M4	4	4.5	276	112	150	2600	29.7	7.8
M3	4	4.5	276	101	135	2500	26.3	6.9
4045DFM70								
M2	2, 3, 4	4.5	276	60	80	2500	17.5	4.6
4045DFM50								
M2	4	4.5	276	63	85	2500	17.3	4.6
M1	4	4.5	276	56	75	2400	15	4

Emissions rating:

1. MARPOL Annex VI compliant
2. EPA Marine Tier 2
3. NRRM (97/68/EC) as amended
4. IMO Exempt

Ratings are subject to change.

Engine model	Length		Width		Height		Weight, dry		Maximum installed angle	
	mm	in	mm	in	mm	in	kg	lb	Front up	Front down
4045TFM75	1056	41.6	827	32.6	912	35.9	462	1019	15	0
4045TFM50	1056	41.6	827	32.6	912	35.9	462	1017	15	0
4045DFM70	923	36.3	758	29.8	902	35.5	437	963	15	0
4045DFM50	923	36.3	758	29.8	902	35.5	437	961	15	0

PowerTech

6.8L marine engines

- Keel-cooled or heat exchanger configurations
- Turbocharged, non-aftercooled or turbocharged with air-to-seawater or air-to-coolant aftercooling
- Feature constant power to 400 rpm below rated speed
- Excellent choice for recreational boats, launches, work boats, trawler yachts, and patrol craft



Engine model	Emissions rating	Displacement		Rated power		Rated speed	Rated fuel consumption	
		L	cu in	kW	hp	rpm	L/hr	gal/hr
6068SFM75								
M5	1, 2, 3*	6.8	414	298	400	2800	77.6	20.5
M4	1, 2, 3	6.8	414	265	355	2700	66.8	17.7
M3	1, 2, 3	6.8	414	239	321	2600	60.2	15.9
M2	1, 2, 3	6.8	414	209	280	2500	52.3	13.8
M1	1, 2, 3	6.8	414	186	249	2400	47.2	12.5
6068SFM50								
M5	1, 2, 3	6.8	414	224	300	2600	59.1	15.6
M4	1, 2, 3	6.8	414	199	267	2500	51.6	13.6
M3	1, 2, 3	6.8	414	176	236	2400	45.5	12
6068AFM75								
M4	1, 2, 3	6.8	414	246	330	2600	65.2	17.2
M3	1, 2, 3	6.8	414	224	300	2500	57.8	15.3
M2	1, 2, 3	6.8	414	198	265	2400	56.2	13.5
M1	1, 2, 3	6.8	414	172	230	2300	43.7	11.5
6068TFM75								
M3	1, 2, 3	6.8	414	150	201	2600	44.1	11.7
M2	1, 2, 3	6.8	414	133	178	2500	38.3	10.1
M1	2, 3, 4	6.8	414	118	158	2400	33.7	8.9
6068TFM50								
M4	1	6.8	414	168	225	2600	44.3	11.7
M2	1	6.8	414	131	175	2400	34.7	9.2

Emissions rating:

1. MARPOL Annex VI compliant
2. EPA Marine Tier 2
3. NRMM (97/68/EC) as amended
4. IMO Exempt

Ratings are subject to change.

* EPA Recreational Marine

Engine model	Length		Width		Height		Weight, dry		Maximum installed angle	
	mm	in	mm	in	mm	in	kg	lb	Front up	Front down
6068SFM75	1380	54.3	1112	43.8	959	37.8	890	1962	9	0
6068SFM50	1380	54.3	875	34.4	882	34.7	793	1748	9	0
6068AFM75	1021	40.2	860	33.9	937	36.9	812	1790	9	0
6068TFM75	1313	51.7	828	32.6	881	34.7	730	1609	9	0
6068TFM50	1313	51.7	828	32.6	881	34.7	730	1609	9	0

PowerTech 9.0L marine engines

- Heat exchanger cooled
- Turbocharged with air-to-seawater aftercooling
- 4-valve cylinder head
- Electronically controlled HPCR fuel system
- Front or side service
- Excellent choice for patrol craft, launches, workboats, fishing boats, trawler yachts, and sportfishing boats



Engine model	Emissions rating	Displacement		Rated power		Rated speed	Rated fuel consumption	
		L	cu in	kW	hp	rpm	L/hr	gal/hr
6090SFM75								
M4	1, 2, 3	9.0	548	373	500	2400	94.0	24.8
M3	1, 2, 3	9.0	548	317	425	2300	80.4	21.2
M2	1, 2, 3	9.0	548	280	375	2200	70.9	18.7
M1	1, 2, 3	9.0	548	242	325	2100	62.7	16.6
6090AFM75								
M4	1, 2, 3	9.0	548	317	425	2400	77.1	20.4
M3	1, 2, 3	9.0	548	280	375	2300	67.7	17.9
M2	1, 2, 3	9.0	548	242	325	2200	57.0	15.1
M1	1, 2, 3	9.0	548	213	285	2100	49.1	13.0

Emissions rating:

1. MARPOL Annex VI compliant
2. EPA Marine Tier 2
3. NRMM (97/68/EC) as amended
4. IMO Exempt

Ratings are subject to change.

Engine model	Length		Width		Height		Weight, dry		Maximum installed angle	
	mm	in	mm	in	mm	in	kg	lb	Front up	Front down
6090SFM75	1714	67.5	974	38.3	977	38.5	1066	2350	12	0
6090AFM75	1682	66.2	938	36.9	984	38.8	1000	2205	12	0

* Estimated

PowerTech

12.5L marine engines

- Keel-cooled or heat exchanger configurations
- Turbocharged with air-to-seawater aftercooling or air-to-coolant aftercooling
- Feature constant power to 400 rpm below rated speed
- Excellent choice for recreational boats, launches, work boats, trawler yachts, and patrol craft



Engine model	Emissions rating	Displacement		Rated power		Rated speed	Rated fuel consumption	
		L	cu in	kW	hp	rpm	L/hr	gal/hr
6125AFM75								
M4	1, 2, 3	12.5	766	392	526	2100	106.5	28.1
M3	1, 2, 3	12.5	766	339	455	2000	92.1	24.3
M2	1, 2, 3	12.5	766	298	400	1900	67.8	17.9
M1	1, 2, 3	12.5	766	254	341	1800	66.2	17.5

Emissions rating:

1. MARPOL Annex VI compliant
2. EPA Marine Tier 2
3. NRM (97/68/EC) as amended
4. IMO Exempt

Ratings are subject to change.

Engine model	Length		Width		Height		Weight, dry		Maximum installed angle	
	mm	in	mm	in	mm	in	kg	lb	Front up	Front down
6125AFM75	1426	56.1	850	33.5	1138	44.8	1372	3025	12	0

PowerTech 13.5L marine engines

- Heat exchanger cooled
- Turbocharged with air-to-seawater aftercooling
- 4-valve cylinder head
- Feature constant power to 400 rpm below rated speed
- Excellent choice for patrol craft, launches, workboats, fishing boats, trawler yachts, and sportfishing boats

Engine model	Emissions rating	Displacement		Rated power		Rated speed	Rated fuel consumption	
		L	cu in	kW	hp	rpm	L/hr	gal/hr
6135SFM75								
M5	1, 2, 3*	13.5	824	559	750	2200	140.2	37
M4	1, 2, 3	13.5	824	485	650	2100	126	33.3
M3	1, 2, 3	13.5	824	429	575	2000	109.4	28.9
M2	1, 2, 3	13.5	824	373	500	1900	94.0	24.8
M1	1, 2, 3	13.5	824	317	425	1800	79.5	21

Emissions rating:

1. MARPOL Annex VI compliant
2. EPA Marine Tier 2
3. NRRM (97/68/EC) as amended
4. IMO Exempt

Ratings are subject to change.

* EPA Recreational Marine

Engine model	Length		Width		Height		Weight, dry		Maximum installed angle	
	mm	in	mm	in	mm	in	kg	lb	Front up	Front down
6135SFM75	1818	71.6	1022	40.2	1194	47.0	1525	3362	12	0



PowerTech marine generator drive engines



- Quiet, smooth operation
- Preferred provider of generator drive engines worldwide
- Available in 1500 rpm for 50 Hz and 1800 rpm for 60 Hz configurations

Engine model	Emissions rating	Rated speed	Engine prime power		Engine 10% overload power	
			rpm	kW	hp	kW
1500 rpm						
6135SFM75	1,2	1500	334	448	366	492
6090SFM75	1,2	1500	222	298	244	328
6090AFM75	1	1500	195	261	214	287
6068SFM75	1,2	1500	146	196	160	215
6068AFM75	1,2	1500	139	186	153	205
6068TFM75	4	1500	89	119	98	131
6068TFM50	4	1500	89	119	98	131
4045TFM50	4	1500	57	76	63	84
4045TFM75	4	1500	55	74	61	82
4045DFM70	4	1500	40	54	44	59
4045DFM50	4	1500	40	54	44	59
1800 rpm						
6135SFM75	1,2	1800	416	558	458	614
6125AFM75	1,2	1800	300	402	330	443
6090SFM75	1,2	1800	278	373	306	410
6090AFM75	1,2	1800	222	297	244	327
6068SFM75	1,2	1800	174	233	191	256
6068AFM75	1,2	1800	166	223	183	245
6068TFM50	4	1800	115	154	125	168
6068TFM76	2,4	1800	110	148	121	162
4045TFM75	2,4	1800	73	98	80	107
4045TFM50	4	1800	71	95	78	105
4045DFM50	4	1800	48	64	53	71
4045DFM70	2,4	1800	46	62	50	67

Emissions rating:

1. MARPOL Annex VI compliant
2. EPA Marine Tier 2
3. NRMM (97/68/EC) as amended
4. IMO Exempt

Typical prime ratings		Typical 10% overload ratings		Typical generator efficiency
kVA	kWe	kVA	kWe	%
1500 rpm				
366 – 383	293 – 306	403 – 421	322 – 337	88 – 92
244 – 255	195 – 205	268 – 281	215 – 224	88 – 92
214 – 224	171 – 179	235 – 246	188 – 197	88 – 92
160 – 168	128 – 134	176 – 184	141 – 147	88 – 92
153 – 160	122 – 128	169 – 176	135 – 141	88 – 92
98 – 102	78 – 82	108 – 113	86 – 90	88 – 92
98 – 102	78 – 82	108 – 113	86 – 90	88 – 92
62 – 65	50 – 52	68 – 71	55 – 57	88 – 92
60 – 64	48 – 51	66 – 70	53 – 56	88 – 92
44 – 46	35 – 37	48 – 51	39 – 41	88 – 92
44 – 46	35 – 37	48 – 51	39 – 40	88 – 92
1800 rpm				
459 – 480	367 – 383	504 – 526	403 – 421	88 – 92
330 – 345	264 – 276	363 – 378	290 – 304	88 – 92
305 – 320	244 – 256	336 – 353	269 – 282	88 – 92
244 – 255	195 – 204	269 – 280	215 – 224	88 – 92
191 – 200	153 – 160	210 – 220	168 – 176	88 – 92
183 – 191	146 – 153	201 – 210	161 – 168	88 – 92
124 – 132	99 – 106	136 – 145	108 – 116	88 – 92
121 – 126	97 – 101	133 – 138	106 – 111	88 – 92
80 – 84	64 – 67	88 – 92	70 – 74	88 – 92
78 – 81	62 – 65	86 – 89	68 – 71	88 – 92
52 – 55	42 – 44	58 – 61	47 – 49	88 – 92
50 – 53	40 – 42	55 – 58	44 – 46	88 – 92

Ratings are subject to change.

PowerTech radiator-cooled generator drive engines

Engine model	Emissions rating	Rated speed	Engine power standby		Standby ratings	
		rpm	kW	hp	kVA	kWe [†]
PowerTech M 1500 rpm						
3029TFG80	3, 4	1500	31	42	32–34	25–27
3029HFG80	3, 4	1500	41	55	43–45	35–36
4045HFG81	3, 4	1500	63	84	67–70	53–56
PowerTech E 1500 rpm						
4045HFG82	3, 4	1500	83	111	89–93	71–74
4045HFG82	3, 4	1500	103	138	108–114	87–91
4045HFG82	3, 4	1500	123	165	128–134	102–107
6068HFG82	1, 3	1500	153	205	159–167	127–133
6068HFG82	1, 3	1500	202	271	213–223	170–179
6090HFG84	1, 3	1500	253	339	266–278	213–223
6090HFG84	1, 3	1500	304	408	323–338	258–271
PowerTech M 1800 rpm						
3029TFG80	3, 4	1800	35	47	35–37	28–30
3029HFG80	3, 4	1800	46	62	48–50	38–40
4045HFG81	3, 4	1800	67	90	69–73	56–58
PowerTech E 1800 rpm						
405TF285	1, 2, 4	1800	74	99	76–79	61–63
4045HFG82	3, 4	1800	86	115	90–95	72–76
4045HFG82	3, 4	1800	106	142	108–114	87–91
4045HFG82	3, 4	1800	126	169	126–132	101–106
6068HFG82	1, 3	1800	156	209	156–164	125–131
6068HFG82	1, 3	1800	212	284	218–228	174–183
6090HFG84	1, 3	1800	258	346	267–280	213–224
6090HFG84	1, 3	1800	315	422	331–347	265–277

Emissions rating:

- MARPOL Annex VI compliant
- EPA Marine Tier 2
- NRMM (97/68/EC) as amended
- IMO Exempt

Engine power prime		Prime ratings		Typical generator efficiency	Typical fan power	GSPU* model
kW	hp	kVA	kWe [†]	%	kW	
PowerTech M 1500 rpm						
28	38	29–31	24–25	88–92	1.3	3029TFU80
37	50	39–41	31–33	88–92	1.4	3029HFU80
57	77	61–63	48–51	88–92	2.0	4045HFU81
PowerTech E 1500 rpm						
76	101	81–84	64–67	88–92	2.0	4045HFU82
94	126	98–103	79–82	88–92	4.0	4045HFU82
112	150	116–121	92–97	88–92	6.0	4045HFU82
139	187	144–151	115–121	88–92	7.3	6068HFU82
184	246	193–202	154–162	88–92	7.3	6068HFU82
230	309	240–252	192–201	90–94	15.2	6090HFU84
277	371	292–306	234–245	90–94	15.2	6090HFU84
PowerTech M 1800 rpm						
31	42	32–34	26–27	88–92	2.2	3029TFU80
42	56	43–45	34–36	88–92	2.4	3029HFU80
61	82	63–66	50–53	88–92	3.4	4045HFU81
PowerTech E 1800 rpm						
67	90	68–71	54–57	88–92	5.2	N/A
78	105	82–86	65–69	88–92	3.4	4045HFU82
96	129	98–103	78–82	88–92	6.7	4045HFU82
115	154	113–119	91–95	88–92	10.3	4045HFU82
142	190	140–148	112–118	88–92	12.6	6068HFU82
193	259	197–206	157–165	88–92	12.6	6068HFU82
235	315	241–252	192–202	90–94	18.9	6090HFU84
287	384	299–313	239–251	90–94	18.9	6090HFU84

*Generator set power unit (GSPU). A GSPU is a John Deere factory-built gen-set power unit, based on a bare engine with mounting pads, cooling package and air filter.

**50 Hz/60 Hz dual frequency is a standard feature on the entire EU Stage III A range.

[†]Electrical power is calculated from the typical generator efficiency and fan power percentages shown. Applications may vary.

PowerTech auxiliary drive engines

- Variable speed, radiator cooled engines that can be used to run auxiliaries such as pumps, winches, deck cranes, and hydraulics
- Ratings from 36 – 559 kW (48 – 750 hp) available in 2.9L to 13.5L displacements
- Engine models available in every required emissions level from non-certified engines up to current tier levels (Marine Tier 2 models shown)



Variable speed engines

Engine model	Emissions rating	Displacement		Rated power		Rated speed	Rated fuel consumption	
		L	cu in	kW	hp	rpm	L/hr	gal/hr
6068HF475	1, 2	6.8	414	187	250	2200	46	12.1
6090HF485	1, 2	9.0	548	280	375	2200	68.6	18.1
6135HF485	1, 2	13.5	824	448	600	2100	112.5	29.7

Emissions rating:

1. MARPOL Annex VI compliant
2. EPA Marine Tier 2
3. NRRM (97/68/EC) as amended
4. IMO Exempt

Ratings are subject to change.

Engine model	Length		Width		Height		Weight, dry	
	mm	in	mm	in	mm	in	kg	lb
6068HF475	1161	45.7	627	24.7	1044	41.1	587	1294
6090HF485	1208	47.6	630	24.8	1113	43.8	901	1986
6135HF485	1334	52.5	855	33.7	1512	59.5	1493	3292



Warranty and service

Best warranty on the water — by far

Whether you're going to a work site or heading out to relax — it's nice to know that you're taking the best marine engine warranty with you. The John Deere warranty has the longest, most complete coverage of the major marine engine manufacturers. While others include only major components, our warranty covers everything. Plus, you get even longer worry-free cruising with our free 5-year/2,000-hour extended warranty for non-revenue-generating applications.* Extended warranties up to five years are also available for commercial applications worldwide.* See your John Deere marine dealer or engine distributor for details.

*Conditions apply. See warranty registration.

Less fuel

The efficiency of John Deere marine engines makes a big difference in your fuel costs. A unique combustion chamber and electronically controlled fuel injection delivers the lowest fuel consumption levels on the market. In addition, thanks to high torque, our engines can be used at lower rpms. You can travel farther and get more out of every tank when you choose John Deere marine engines.

Easy access to parts and service

With more than 4,000 John Deere service locations worldwide, you're never far from help when you need it.

Log on to www.JohnDeere.com/dealer to find the service dealer nearest you.



Worldwide locations

North America, South America, Brazil, and Caribbean

John Deere Power Systems
3801 West Ridgeway Avenue
P.O. Box 5100
Waterloo, IA 50704-5100
Phone: +1 800 533 6446 (U.S.)
Phone: +1 319 292 6060 (Canada)
Fax: +1 319 292 5075
E-mail: jdpower@JohnDeere.com

Mexico and Central America

Industrias John Deere S.A. de C.V.
Boulevard Diaz Ordaz No. 500
Garza Garcia, Nuevo Leon 66210
Mexico
Phone: +52 81 8288 1212
Fax: +52 81 8288 8284
E-mail: mexweb@JohnDeere.com

Europe, Africa, and Middle East

John Deere Power Systems
Usine de Saran
La Foulonnerie – B.P. 11013
45401 Fleury-les-Aubrais Cedex
France
Phone: +33 2 38 82 61 19
Fax: +33 2 38 84 62 66
E-mail: jdmarineengine@JohnDeere.com

Australia and New Zealand

John Deere Limited
Power Systems Division
P.O. Box 1545, Browns Plains BC
QLD 4118 Australia
Phone: +61 7 3802 3222
Fax: +61 7 3803 6555
E-mail: 23powersystems@JohnDeere.com
www.JohnDeere.com.au
www.JohnDeere.co.nz

Far East

John Deere Asia (Singapore) Pte. Ltd.
#06-02/03 Alexandra Point
438 Alexandra Road
119958 Singapore
Phone: +65 (68) 79 88 00
Fax: +65 (62) 78 03 63
E-mail: LiewLeongKong@JohnDeere.com



JOHN DEERE



This literature has been compiled for worldwide circulation. While general information, pictures and descriptions are provided, some illustrations and text may include finance, credit, insurance, product options and accessories NOT AVAILABLE in all regions. PLEASE CONTACT YOUR LOCAL DEALER FOR DETAILS. John Deere reserves the right to change specification and design of all products described in this literature without notice.

